

Introducing the **WIT-50XA** Series Arrowhead Cable Ties

Features and Benefits

- Integrated arrowhead mount reduces inventory and saves time in application
- Tension wings provide pressure to the panel stabilizing the mount
- Bundling of cables can be done before or after mounting into the panel

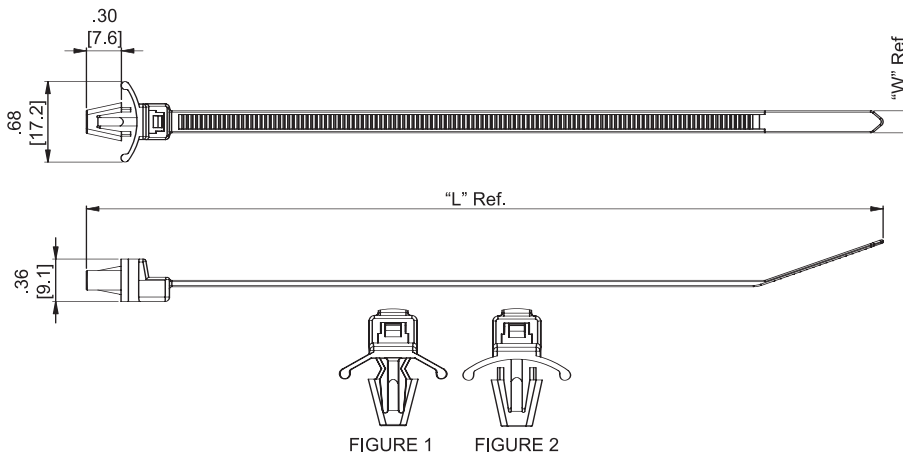
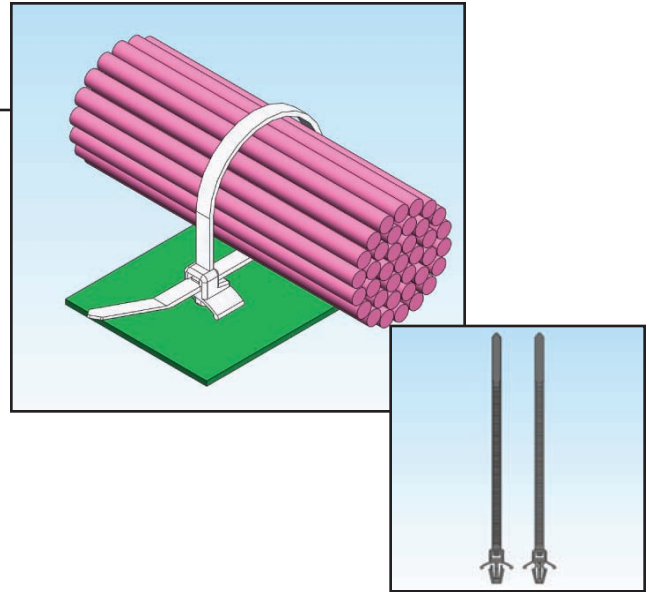

Markets

- White Goods
- Brown Goods
- Telecommunications
- Security Systems
- Construction
- Office Equipment

Other Related Richco Product Solutions



Standard Material: UL94 V2 Nylon 6/6, RMS-01 Color: Natural	Fig.	Min. Loop Tensile Strength lb (kg)	"L" Length Ref.	Max. Bundle Diameter	"W" Width	Mounting Hole Diameter	Panel Thickness	Standard Pack	Color & Material Variations Suffix			
									UL94 V0 Nylon 6/6, RMS-19 Color: Natural	UL94 V2 Nylon 6/6, RMS-01 Color: Black	High Temp. Nylon 4/6, RMS-109 Color: Natural	UV Stabilized Nylon, RMS-46A Color: Black
									Replace -01 with -V0	Add BK	Add -HT	Add -UVB
WIT-18RA-01	1	18 (8)	4.29 (109)	.83 (21)	.10 (2.5)	.19 (4.8)	.06 (1.6)	1000	SPECIAL	SPECIAL	SPECIAL	SPECIAL
WIT-50SA-01		5.24 (133)	.91 (23)	.25 (6.4)	.19 (4.8)	500						
WIT-50SRA-01		6.81 (173)	1.42 (36)			1000						
WIT-50RA-01		7.80 (198)	1.69 (43)	500								
WIT-50SA-1-01	2	50 (22)	5.24 (133)	.91 (23)	.25 - .27 (6.4 - 6.8)	.03 - .08 (0.8 - 2)	.06 (1.6)	1000	SPECIAL	SPECIAL	SPECIAL	SPECIAL
WIT-50SRA-1-01			6.81 (173)	1.42 (36)				500				
WIT-50RA-1-01			7.80 (198)	1.69 (43)				1000				
			500									