

## Introducing the *SCCA & SCCB* Standoff Cable Clamps

### Features and Benefits

- Press-through cable entry reduces assembly time and working conditions on the assembly line
- Installers are not required to lock or twist the part to lock in the cable
- Design of cable entry provides a smooth entry into the clamp as well as a minor locking feature on the SCCB
- Cupped base provides better coverage of the hole than traditional tension wings
- Cup prevents contaminants moving through the hole and also provides more stability in the panel

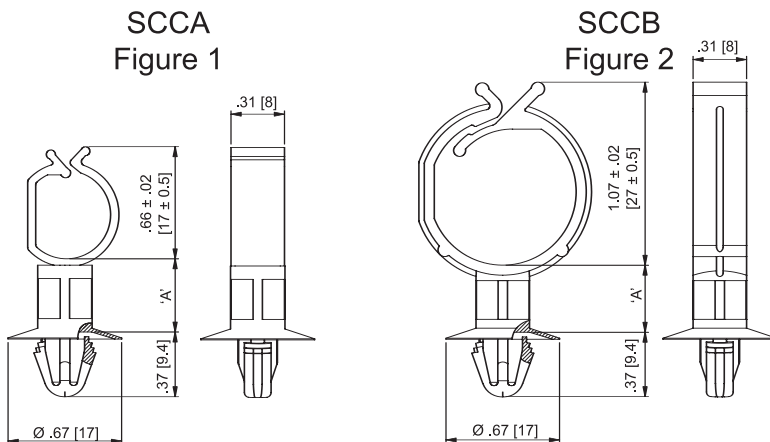
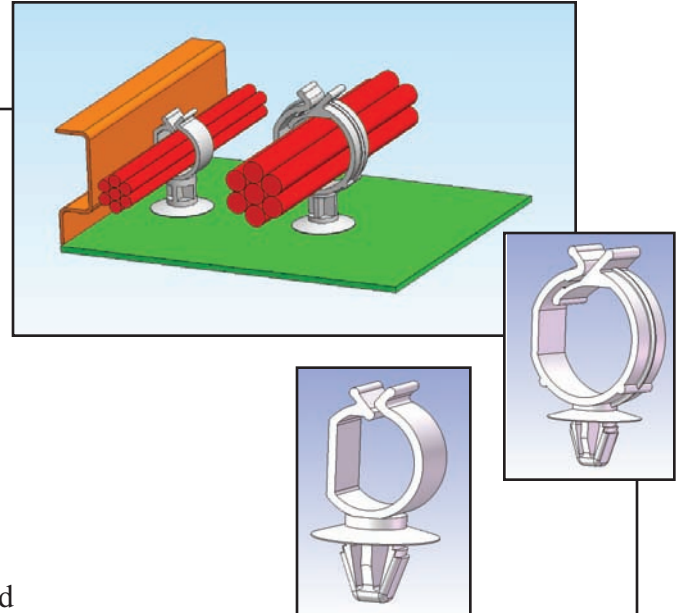

### Markets

- White Goods
- Brown Goods / Consumer Electronics
- Office Equipment
- Security Systems
- Telecommunications

### Other Related Richco Product Solutions

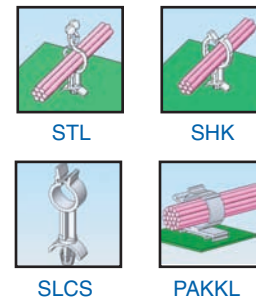

Standard Pack: 1000 per bag						
UL94 V-2 Nylon 6/6, RMS-01, Color: Natural	UL94 V-0 Nylon 6/6, RMS-19, Color: Natural	"A"	Max. Cable Bundle Diameter	Hole Diameter	Panel Thickness	Fig.
SCCA-1-01	SCCA-1-19	.158 (4)	Ø .433 (Ø 11)	Ø .256 - .276 (Ø 6.5 - 7)	.024 - .079 (0.6 - 2)	1
SCCA-2-01	SCCA-2-19	.236 (6)				
SCCA-3-01	SCCA-3-19	.315 (8)				
SCCA-4-01	SCCA-4-19	.394 (10)				
SCCA-5-01	SCCA-5-19	.472 (12)				
SCCB-1-01	SCCB-1-19	.158 (4)	Ø .866 (Ø 22)			2
SCCB-2-01	SCCB-2-19	.236 (6)				
SCCB-3-01	SCCB-3-19	.315 (8)				
SCCB-4-01	SCCB-4-19	.394 (10)				
SCCB-5-01	SCCB-5-19	.472 (12)				
SCCB-6-01	SCCB-6-19	1.181 (30)				

Available in Black Color and High Temperature Material by special order.