

Introducing the **FTH-3A-01** Pressure Hold Cable Tie Holder

Features and Benefits

- Allows pre-assembly of the cable tie into the holder and holds it in place
- Provides a pressure hold onto the cable tie
- Accepts WIT-18 thru -50 and QTE-18 thru -50 cable ties

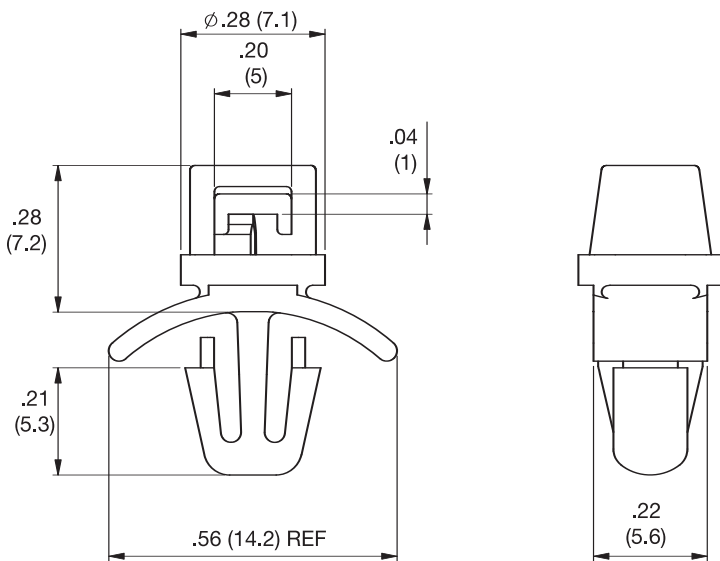
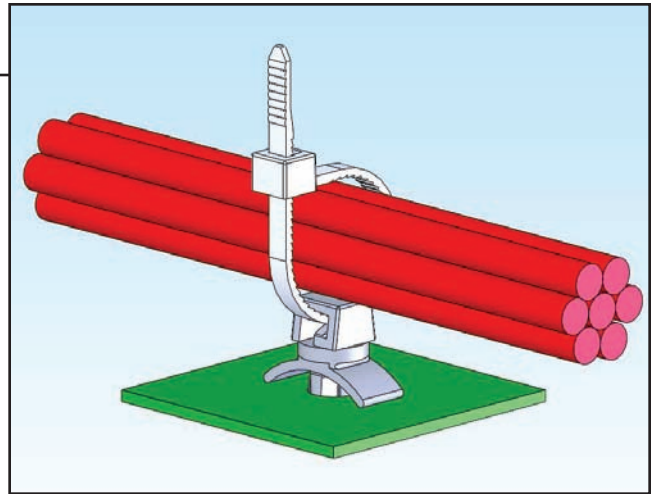

Markets

- Automotive
- White Goods
- Heating, Ventilation and Air Conditioning
- Telecommunications

Other Related Richco Product Solutions

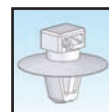

FTH-33

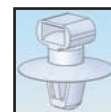

FTH-29-01



FTH-6-01

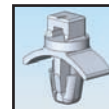

FTH-30



WIT



FTH-5

Material: Nylon 6/6, RMS-01* Color: Natural

Standard Pack: 1,000 per bag

Part No.	Standard Pack: 1,000 per bag		
	Hole Dia ± .003 (.08)	Panel Thickness	Accepts Cable Ties
FTH-3A-01	.21 (5.3)	0.03-0.08 (0.8-2)	WIT-18 thru 50, QTE-18 thru QTE-50

*Parts are available in UL94 V0 Material, RMS-19 by special order. To order, replace -01 with -19.