

Introducing the **FTH-39** Cable Tie Holder

Features and Benefits

- Low profile head design saves space
- Panel fastener and tie holder are combined in one product
- Allows preassembly of cable ties
- Holds the cable tie in place after preassembly

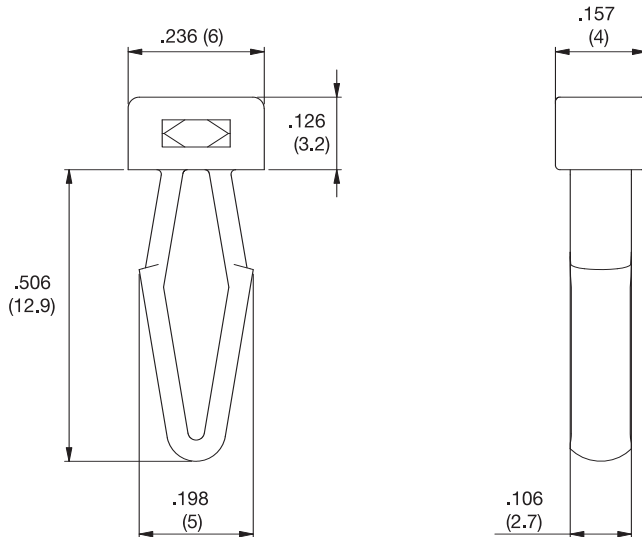
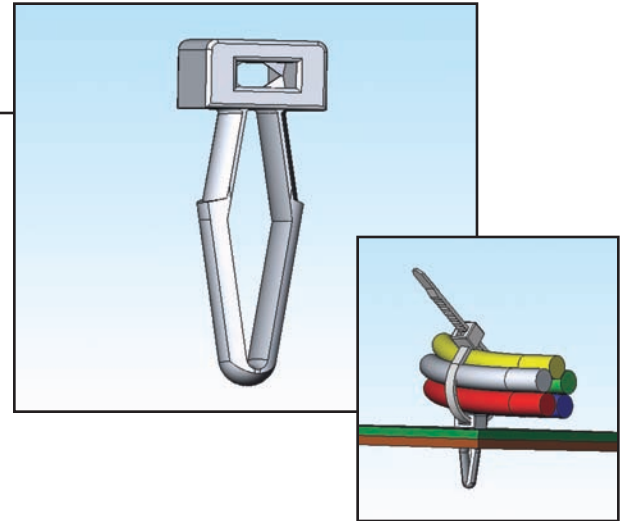

Markets

- Telecommunication
- Consumer Electronics
- Appliance
- Electrical

Other Related Richco Product Solutions

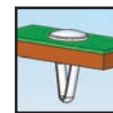

DF



WIT

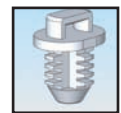

FTH-15

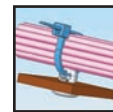

FTH-9

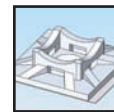

FTH-7



WIT-18RA

Color: Natural	Standard Pack: 1000 per bag			
Part Number	Used with Ties	Panel Hole Size	Panel Thickness	Material
FTH-39-1-01	WIT-18	.126 (3.2)	.039-.177 (1-4.5)	UL94 V2 Nylon 6/6 RMS-01
FTH-39-1-19				UL94 V0 Nylon 6/6 RMS-19

