

NEW!

SpotFast® Fasteners

washer allows consistent pivoting of two metal panels

The PEM® SpotFast® self-clinching fastener from PennEngineering® allows pivoting of two sheets of metal. A wave washer provides the consistent torsion to allow repeatable hinging. The fastener installs smooth with the top sheet, and flush or sub-flush with the bottom sheet. Squeezing the fastener into place causes a cold-flow of panel material into the fastener's two separate clinch profiles. This fastener is capable of joining two dissimilar metals, including unequal thicknesses.



Look for the PEM® "dimple" trademark.



SpotFast fastener used as a single flush-mounted pivot point.



Patent pending.

Features and Benefits

- ▶ Alternative to riveting.
- ▶ Washer allows pivoting with consistent force.
- ▶ Standard parts install into sheets as thin as .031"/0.8mm.
- ▶ Flush mounted.
- ▶ Minimal space requirements.
- ▶ Can be installed blind into bottom (Panel 2) panel.
- ▶ Can join dissimilar metals.
- ▶ RoHS compliant.

Installation

- Step 1:** Punch or drill properly sized mounting hole in both panels. Do not perform any secondary operations such as deburring.
- Step 2:** Using only Panel 1, with the punch and anvil surfaces parallel, apply squeezing force until the fastener is flush with the top of Panel 1.
- Step 3:** Place washer over installed fastener (concave side facing up), then place Panel 2 over fastener. Apply squeezing force. Keep .015-.020" / 0.38-0.51mm nominal gap between two sheets after installation.

Anvil Dimensions

Size	C ±0.13/±.005 (mm) / (.in.)	Punch Part No.	Anvil Part No.
SFW-3	3.05 / .120	975200048	970200229300
SFW-5	5.05 / .199	975200048	970200020300

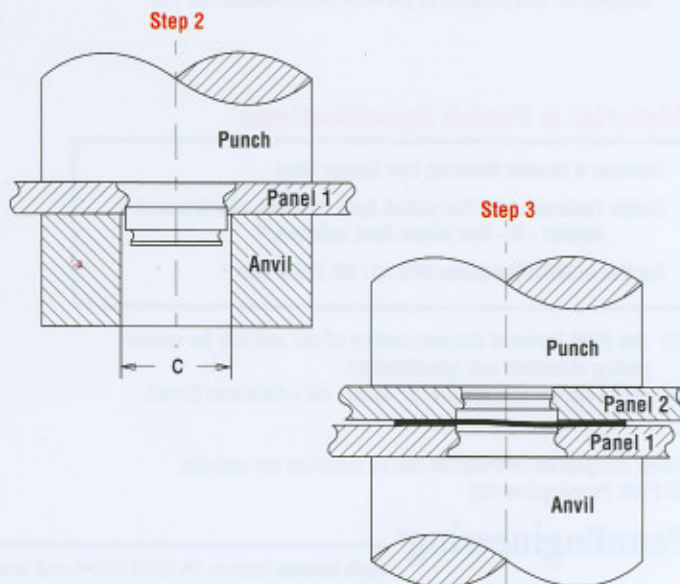

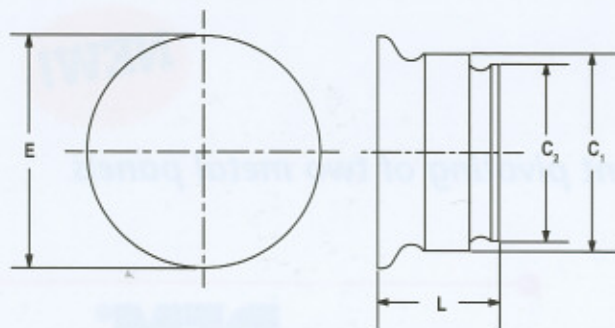

Part Number Designation

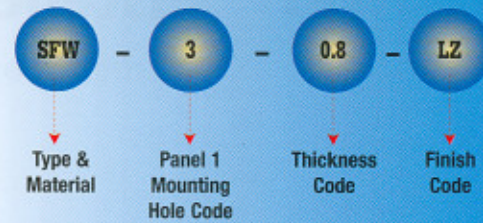

Type and Size	Thickness Code	Panel 1				Panel 2				C ₁ Max.		C ₂ Max.		E Max.		L Max.		Min. Dist Hole C/L To Edge	
		Thickness ±0.08mm / ±.003"		Mounting Hole +0.08mm / +.003" - .000"		Thickness Min. (1)		Mounting Hole +0.08mm / +.003" - .000"		mm	in.	mm	in.	mm	in.	mm	in.	mm	in.
		mm	in.	mm	in.	mm	in.	mm	in.	mm	in.	mm	in.	mm	in.	mm	in.	mm	in.
SFW-3	0.8	0.8	.031	3	.118	0.8	.031	2.5	.098	2.98	.117	2.48	.097	3.53	.139	2.09	.082	2.54	.1
SFW-3	1.0	1	.039	3	.118	1	.039	2.5	.098	2.98	.117	2.46	.097	3.76	.148	2.49	.098	2.54	.1
SFW-3	1.2	1.2	.047	3	.118	1.2	.047	2.5	.098	2.98	.117	2.46	.097	3.76	.148	2.90	.114	2.54	.1
SFW-3	1.6	1.6	.063	3	.118	1.6	.063	2.5	.098	2.98	.117	2.46	.097	3.76	.148	3.71	.146	2.54	.1
SFW-5	0.8	0.8	.031	5	.197	0.8	.031	4	.157	4.98	.196	3.97	.156	5.56	.219	1.98	.078	3.6	.14
SFW-5	1.0	1	.039	5	.197	1	.039	4	.157	4.98	.196	3.97	.156	5.56	.219	2.39	.094	3.6	.14
SFW-5	1.2	1.2	.047	5	.197	1.2	.047	4	.177	4.98	.196	3.97	.156	5.56	.219	2.79	.110	3.6	.14
SFW-5	1.6	1.6	.063	5	.197	1.6	.063	4	.177	4.98	.196	3.97	.156	5.56	.219	3.61	.142	3.6	.14

(1) Fastener will provide flush application at minimum sheet thickness.

Performance Data⁽²⁾

Type and Size	Thickness Code	Installation into Panel 1				Installation into Panel 2				Pushout of Panel 2			
		Cold-rolled Steel		Aluminum		Cold-rolled Steel		Aluminum		Cold-rolled Steel		Aluminum	
		kN	lbs.	kN	lbs.	kN	lbs.	kN	lbs.	N	lbs.	N	lbs.
SFW-3	0.8	4.5	1010	2.5	560	3	675	2	450	350	78	85	19
SFW-3	1.0	5.5	1240	3.5	780	4.5	1010	2	450	375	84	140	31
SFW-3	1.2	6	1350	3.5	780	5	1125	2	450	500	112	250	56
SFW-3	1.6	7	1575	4	900	6	1350	2.5	560	780	175	340	76
SFW-5	0.8	7	1575	3.5	780	8	1800	4	900	350	78	270	61
SFW-5	1.0	7	1575	3.5	780	8.5	1910	5	1125	380	153	425	96
SFW-5	1.2	7	1575	4	900	8.5	1910	5	1125	925	208	510	115
SFW-5	1.6	9	2025	5	1125	10	2250	5	1125	1450	326	600	135

(2) Installation and pushout values reported are averages when all installation specifications and procedures are followed. Variations in mounting hole size, sheet material, and installation procedure will affect this data. Performance testing of this product in your application is recommended. We will be happy to provide samples for this purpose or perform the installation for you.

Material & Finish Specifications

Fastener & Washer Material: Low Carbon Steel
Finish: Fastener - LZ - Zinc plated, 5µm, colorless, with lubricant ⁽³⁾
 Washer - ZI - Zinc plated, 5µm, colorless ⁽³⁾
For Use In Sheet Hardness: HRB 80 / HB 150 or less ⁽⁴⁾

(3) See PEM Technical Support section of our web site for related plating standards and specifications.
 (4) HRB - Hardness Rockwell "B" Scale. HB - Hardness Brinell.

RoHS compliance information can be found on our website.
 © 2008 PennEngineering.



SpotFast fastener with washer installed in sheets.

Specifications subject to change without notice.
 Check our website for the most current version of this bulletin.

PennEngineering®



North America: Danboro, PA 18916 USA • E-mail: info@pemnet.com • Tel: +1-215-766-8853 • Fax: +1-215-766-0143 • 800-237-4736 (USA Only)
U.K. And Europe: Doncaster, England • E-mail: uk@pemnet.com Tel: +44 (0)1302 765700 • Fax: +44 (0)1302 367580
Asia/Pacific: Singapore • E-mail: singapore@pemnet.com • Tel: +65-6-745-0660 • Fax: +65-6-745-2400
 Shanghai, China • E-mail: china@pemnet.com • Tel: +86-21-5868-3688 • Fax: +86-21-5868-3988

Visit our PEMNET™ Resource Center at www.pemnet.com