



MODEL 9308 LOCK-IN/LOCK-OUT

MODEL 9307 LOCK-OUT

APPLICATIONS: Designed for use in heavy-duty mobile and vehicular applications where a lock-in and lock-out are required. **This product is covered by U.S. and various foreign patents issued and/or pending.**

Extra Heavy-Duty, Full Extension
Up to 500-lb. [227 kg.] Load Rating*
Optional Accessory Platform Brackets

- * Hole not available on the 9308-12 slide only
- o Hole not available on the 9308-22 only
- Available on 9308-48 and 9308-60 slides only
- △ Available on 9308-60 slides only
- Slide's lock-out for vertical mount only
- ◇ Depress lever to release slide from it's closed position, use the same lever to release the slide from it's locked out position

inches
[mm]

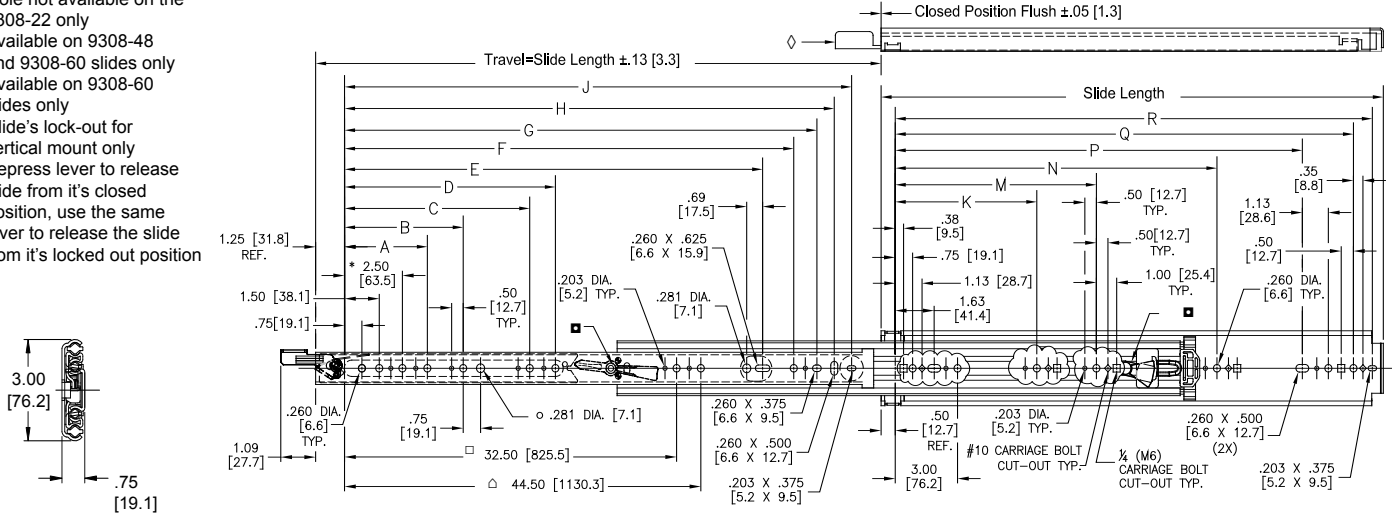

- Finish** Clear electroplate (C) only
- Length** Even lengths: 12"-36" [305 mm-914 mm]
40", 42", 48", and 60" [1016 mm, 1066.8 mm, 1219 mm, 1524 mm]
- Travel** Full extension
- Height** 3.00" [76.2 mm]
- Side Space** .75" (+.031, -.000) [19.1 mm (+.79, -.00)]
- Movement** Steel ball bearings
- Load Rating**
 - Moderate Use 500 lbs. [227.3 kg]
 - Frequent Use 400 lbs. [181.8 kg]
 - Mobile (Vehicular) 300 lbs. [136.4 kg]

- Mounting** Side mount **Only** (optional accessory platform brackets available)
- Features** Non-disconnect 9308 lock-in and lock-out. 9307 lock-out only. Bumper provides extra silencing during drawer closure.
- Companion** 9301 non-locking slide can be used in conjunction with locking 9307 or 9308 (see 9301 data sheet)
- Hardware** Customer supplied (see back page)

Caution: This slide must never be used as a pull-out step, platform, or any other application supporting human weight as injury may result.

Part Number	Slide Length	Slide Travel	A	B	C	D	E	F	G	H	J	K	M	N	P	Q	R
9308-12	12.00 [304.8]	12.00 [304.8]						6.06 [153.9]	7.06 [179.3]	7.81 [198.4]					8.00 [203.2]	10.25 [260.4]	11.00 [279.4]
9308-14	14.00 [355.6]	14.00 [355.6]						8.06 [204.7]	9.06 [230.1]	9.81 [249.2]					10.00 [254.0]	12.25 [311.2]	13.00 [330.2]
9308-16	16.00 [406.4]	16.00 [406.4]						10.06 [255.5]	11.06 [280.9]	11.81 [299.9]					12.00 [304.8]	14.25 [361.9]	15.00 [381.0]
9308-18	18.00 [457.2]	18.00 [457.2]	5.00 [127.0]					12.06 [306.3]	13.06 [331.7]	13.81 [350.8]					14.00 [355.6]	16.25 [412.8]	17.00 [431.8]
9308-20	20.00 [508.0]	20.00 [508.0]	5.00 [127.0]				11.69 [296.9]	14.06 [357.1]	15.06 [382.5]	15.81 [401.6]					16.00 [406.4]	18.25 [463.6]	19.00 [482.6]
9308-22	22.00 [558.8]	22.00 [558.8]	5.00 [127.0]	7.50 [190.5]			13.69 [347.7]	16.06 [407.9]	17.06 [433.3]	17.81 [452.4]					18.00 [457.2]	20.25 [514.4]	21.00 [533.4]
9308-24	24.00 [609.6]	24.00 [609.6]	5.00 [127.0]	7.50 [190.5]			15.69 [398.5]	18.06 [458.7]	19.06 [484.1]	19.81 [503.2]					20.00 [508.0]	22.25 [565.2]	23.00 [584.2]
9308-26	26.00 [660.4]	26.00 [660.4]	5.00 [127.0]	7.50 [190.5]			17.69 [449.3]	20.06 [509.5]	21.06 [534.9]	21.81 [553.9]					22.00 [558.8]	24.25 [615.9]	25.00 [635.0]
9308-28	28.00 [711.2]	28.00 [711.2]	5.00 [127.0]	7.50 [190.5]			19.69 [500.1]	22.06 [560.3]	23.06 [585.7]	23.81 [604.8]					24.00 [609.6]	26.25 [666.8]	27.00 [685.8]
9308-30	30.00 [762.0]	30.00 [762.0]	5.00 [127.0]	7.50 [190.5]			21.69 [550.9]	24.06 [611.1]	25.06 [636.5]	25.81 [655.6]					26.00 [660.4]	28.25 [717.6]	29.00 [736.6]
9308-32	32.00 [812.8]	32.00 [812.8]	5.00 [127.0]	7.50 [190.5]			23.69 [601.7]	26.06 [661.9]	27.06 [687.3]	27.81 [706.4]					28.00 [711.2]	30.25 [772.4]	31.00 [791.4]
9308-34	34.00 [863.6]	34.00 [863.6]	5.00 [127.0]	7.50 [190.5]		20.50 [520.7]	25.69 [652.5]	28.06 [712.7]	29.06 [738.1]	29.81 [757.1]					30.00 [762.0]	32.25 [823.2]	33.00 [842.2]
9308-36	36.00 [914.4]	36.00 [914.4]	5.00 [127.0]	7.50 [190.5]		20.50 [520.7]	27.69 [703.3]	30.06 [763.5]	31.06 [788.9]	31.81 [807.9]					32.00 [816.4]	34.25 [873.2]	35.00 [892.2]
9308-40	40.00 [1016.0]	40.00 [1016.0]	5.00 [127.0]	7.50 [190.5]	14.50 [368.3]		31.69 [804.9]	34.06 [865.1]	35.06 [890.5]	35.81 [909.5]					36.00 [914.4]	38.25 [970.6]	39.00 [989.6]
9308-42	42.00 [1066.8]	42.00 [1066.8]	5.00 [127.0]	7.50 [190.5]	14.50 [368.3]		33.69 [855.7]	36.06 [915.9]	37.06 [941.3]	37.81 [960.4]					37.00 [939.6]	40.25 [1021.6]	41.00 [1040.6]
9308-48	48.00 [1219.2]	48.00 [1219.2]	5.00 [127.0]	7.50 [190.5]	14.50 [368.3]	20.50 [520.7]	39.69 [1008.1]	42.06 [1068.3]	43.06 [1093.7]	43.81 [1112.8]					44.00 [1117.6]	46.25 [1178.6]	47.00 [1197.6]
9308-60	60.00 [1524.0]	60.00 [1524.0]	5.00 [127.0]	7.50 [190.5]	14.50 [368.3]	20.50 [520.7]	51.69 [1312.9]	54.06 [1373.1]	55.06 [1398.5]	55.81 [1417.8]					56.00 [1422.4]	58.25 [1479.6]	59.00 [1498.6]

* Load rating based on 18" slides mounted in a 32" wide drawer.

See 9301 technical sheet for further load information.

Note: Specified mounting hardware is not included in packaging.

Side Mounting

To install the cabinet (outer) member, first fully extend the slides to provide access to the mounting holes. Be sure slides are parallel. Insert the 1/4" head-hex or pan head screws (M6 Euro) through the horizontal slots.

Attach the drawer to the extended inner members with 1/4" hex-head or pan head screws (M6 Euro) inserted through the vertical slots. Leave all screws loose for final adjustment. Adjust slide positions until movement is smooth. Then tighten all screws; if necessary, use more screws to secure slides and complete installation. See Figure 1.

Carriage Bolt Mounting Considerations

When using carriage bolts, the squared neck of the bolt will extend beyond the cabinet member material thickness. Therefore, carriage bolts must be used with mounting surfaces that allow for the insertion of the protruding neck of the bolt (i.e. aluminum or wood). Otherwise, the mounting surface must have a hole to provide clearance for the protruding neck. This is required to fasten the slides securely to the cabinet. See Figure 4, for the minimum dimensions required for the clearance hole.

Carriage bolts may be used to secure the cabinet members only; carriage bolt mounting holes are not available on the drawer member. Be aware that when using carriage bolt mounting holes, the adjacent holes will become unavailable for mounting.

Note: Platform bracket kits are not compatible with the carriage bolt mounting method.

Side Mounting (Carriage Bolt)

To install the cabinet member (outer) member, first fully extend the slides to provide access to mounting holes. Be sure slides are parallel. Insert the carriage bolts (customer-supplied) through the diamond or square shaped holes. The diamond-shaped holes accommodate #10 type carriage bolts; the square holes accommodate 1/4" (M6 Euro) type carriage bolts. See Figure A.

Attach the drawer to the extended inner members with 1/4" hex-head or pan head screws (M6 Euro). Leave all screws loose for final adjustment. Adjust slide positions until movement is smooth. Then tighten all screws and nuts; if necessary, use more screws to secure slides and complete installation. See Figure 2.

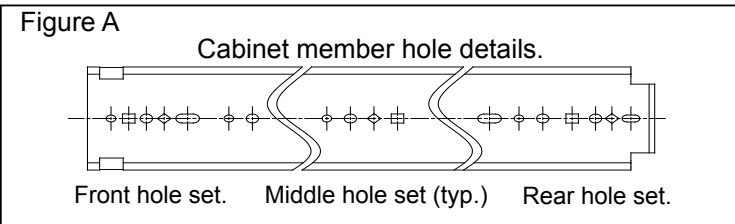

Optional Accessory Platform Brackets

Brackets provide four bottom-mount and two side-mount options. For bottom-mount, one bracket attaches to the slide outer member and the cabinet base. The other bracket attaches to the slide inner member and the platform or tray. For side-mount, the bracket attaches to the slide inner member.

See Figure 3 for examples of both mounting options. When the brackets are used either individually or in combination, they will accommodate all slide lengths. Each kit contains two brackets, four 1/4" hex-head screws, and four 1/4" hex nuts with lock washers. See separate Accessory Platform Bracket Kit data sheet for more information.

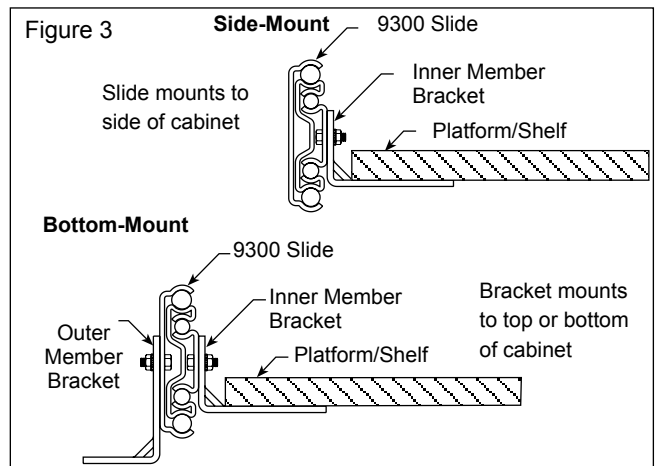
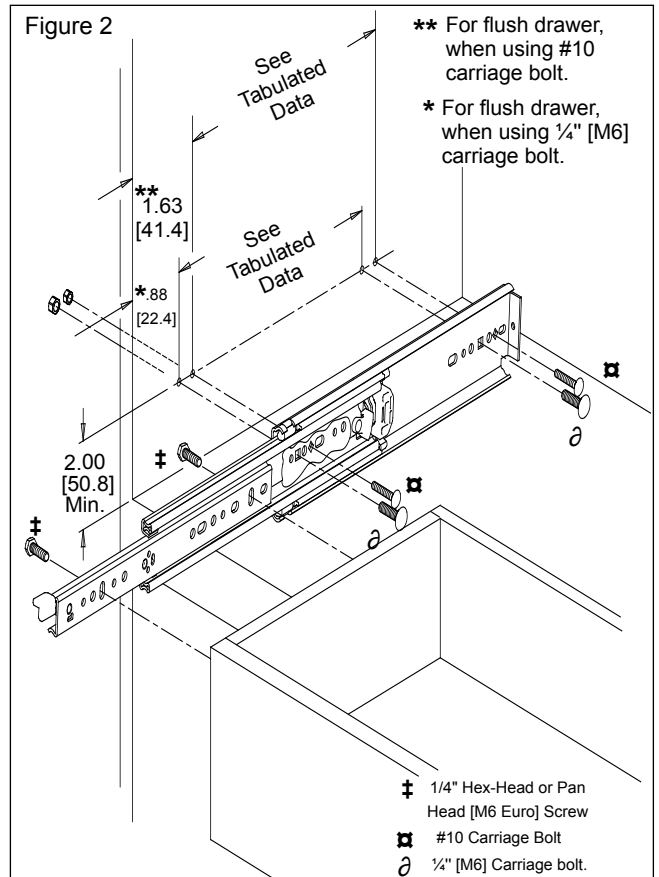
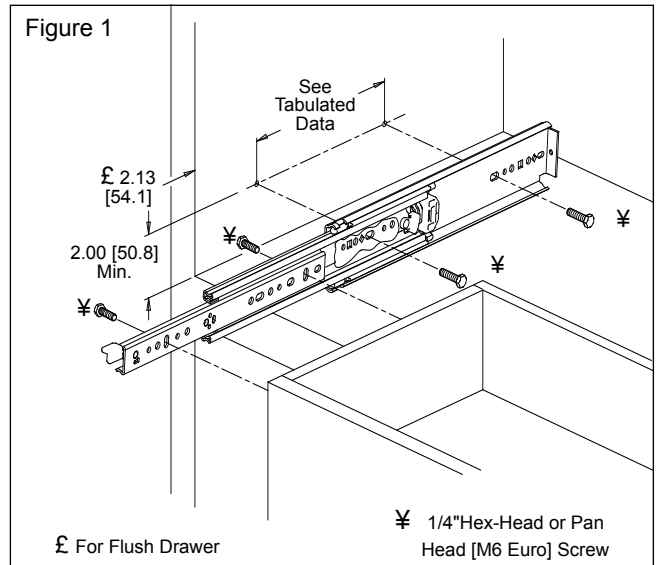

Locking Slide

The locking slide can be used on either the right hand side, left hand side, or both sides of the unit. After the length, specify "L" for left hand locking slide and "R" for right hand locking slide.

Complete your slide order for model 9308 or 9307 locking slide by specifying the following:

4 Each C 9308(07) -22 -L **or**
 4 Each C 9308(07) -22 -R

Total Required Slides _____
 Slide Finish _____
 Locking Slide Model 9308 (07) _____
 Slide Length _____
 Locking Slide Hand _____

NOTE: For applications requiring a lock on both sides, order an equal amount of "L" and "R" hand slides.

9301 Non-Locking Companion Slide

Model 9301 is unhandred and can be used on either the left or right hand side of the unit. For each locking slide ordered, order 1 companion slide.

Complete your slide order for model 9301 companion slide by specifying the following:

4 Each C 9301 -22

Total Required Slides _____
 Slide Finish _____
 Companion Slide Model 9301 _____
 Slide Length _____

See 9301 technical sheet for additional information.

Special packaging is available that includes one standard 9301 and one right-hand 9308. The part number for this is 9308-5. This D-Pack offering is available in the following lengths: 14" - 36", 40", 42", 48", and 60".

Figure 4

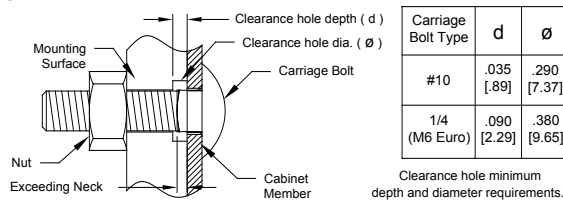

Customer Supplied Mounting Hardware

Mounting Hardware Options (customer-supplied):

Metal Applications:

- 1/4" hex-head or pan head [M6 Euro] screw for .260" [6.6 mm] holes.
- Hex-head; or, pan head [M5 Euro] screw for .203" [5.2 mm] holes.
- #10 carriage bolt for diamond-shaped holes.
- 1/4" [M6 Euro] carriage bolt for square-shaped holes.

Wood Applications:

- 1/4" lag or sheet metal screw.
- #10 lag or sheet metal screw; maximum screw head of .190" [4.8 mm] high by .500" [12.7 mm] diameter for clearance.
- #10 carriage bolt for diamond-shaped holes.
- 1/4" [M6 Euro] carriage bolt for square-shaped holes.

Packaging

Bulk Pack: Slides only. Left and right hand slides packaged in separate boxes.

Slide Lengths: 12" to 20" 8 each per box
 22" to 36" 4 each per box
 40", 42", 48", 60" 2 each per box

Specifications

Slide members: Cold rolled steel
 Ball retainers: Polymer
 Ball bearings: Carburized steel
 RoHS compliant

Note: Specifications, materials, prices, terms, and delivery are subject to change without notice.



ACCURIDE INTERNATIONAL INC.

12311 Shoemaker Avenue
 Santa Fe Springs, CA 90670
 TEL (562) 903-0200
 FAX (562) 903-0208
 www accuride.com

Manufacturing, Engineering, and Sales
 United States • Germany • Japan • Mexico • United Kingdom • China