



# Flexicon Nylon Conduit Fittings Flexilok, PG Hubs

For Flexible, Corrugated Nylon Conduit/Tubing

- For use with Flexicon corrugated conduit/tubing. See pages 1-15 and 1-16.
- One piece fast fit allows for quick installation.
- Slim-line design is a space saver.
- Suitable for use with both coarse and/or fine pitch conduit/tubing.
- All nylon construction resists salt water, weak acids, gasoline, alcohol, oil, grease, and common solvents. This feature is not assessed by UL certification or testing.
- UV Resistant.
- No threading of the conduit/tubing is required to install.
- IP 66 rating—protection against dust and water penetration.
- Low fire hazard. Halogen, sulfur, and phosphorous free.

FITS CONDUIT NOMINAL SIZE	PART NO.		DESCRIPTION	THREAD SIZE	PART DIMENSIONS							
	Black	Gray			A		B		C		D	
					Thread Length	Max Diameter	Max O. A. Length	Clearance Hole				
in	mm	in	mm	in	mm	in	mm	in	mm			
13	F8772	F8773	PG9 13mm FLK13-PG9	PG9	.39	10,0	.80	20,4	1.59	40,5	.60	15,2
16	F8774	F8775	PG9 16mm FLK16-PG9	PG9	.39	10,0	.90	22,9	1.65	42,0	.73	18,5
13	F8776	F8777	PG11 13mm FLK13-PG11	PG11	.39	10,0	.80	20,4	1.59	40,5	.60	15,2
16	F8778	F8779	PG11 16mm FLK16-PG11	PG11	.39	10,0	.90	22,9	1.65	42,0	.73	18,5
16	F8780	F8781	PG13 16mm FLK16-PG13	PG13,5	.39	10,0	.90	22,9	1.65	42,0	.80	20,3
21	F8782	F8783	PG13 21mm FLK21-PG13	PG13,5	.43	11,0	1.12	28,5	1.76	44,6	.89	22,6
16	F8784	F8785	PG16 16mm FLK16-PG16	PG16	.39	10,0	.90	22,9	1.71	43,4	.80	20,3
21	F8786	F8787	PG16 21mm FLK21-PG16	PG16	.43	11,0	1.12	28,5	1.81	46,0	.89	22,6
28	F8788	F8789	PG21 28mm FLK28-PG21	PG21	.47	12,0	1.43	36,3	1.99	50,6	1.12	28,5
34	F8790	F8791	PG29 34mm FLK34-PG29	PG29	.47	12,0	1.69	43,0	2.11	53,6	1.47	37,3

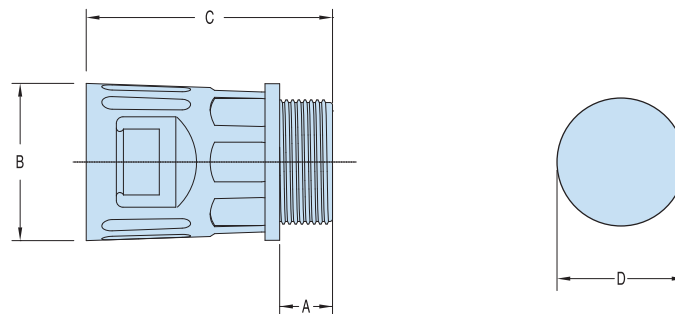

Quick  
Specs

Material	Nylon PA66
Certifications	CE Approved as per EN61386
Temperature Rating	-58°F (-50°C) to 275°F (135°C)
IP Rating	IP 66